

MATERIAL:	BRASS
SURFACE:	PLAIN FINISH

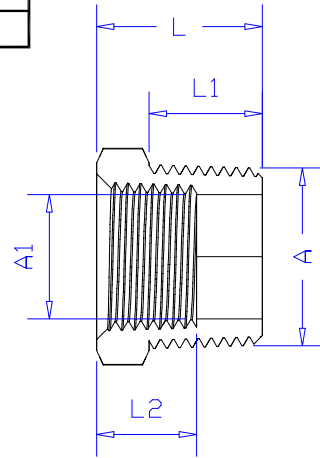

VIEW: B-B

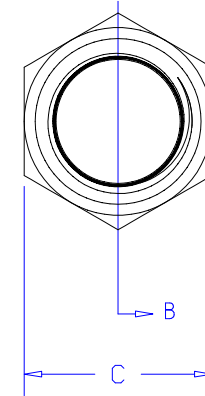

	A	A1	C	L	L1	L2
110-N1-N2	1/4-18NPT	1/8-27NPT	14.80	15.90	11.05	8.75
110-N1-N3	3/8-18NPT	1/8-27NPT	17.45	18.25	13.10	10.10
110-N2-N3	3/8-18NPT	1/4-18NPT	17.45	18.25	13.10	14.30
110-N1-N4	1/2-14NPT	1/8-27NPT	22.20	20.60	14.25	11.10
110-N2-N4	1/2-14NPT	1/4-18NPT	22.20	20.65	14.95	12.70
110-N3-N4	1/2-14NPT	3/8-18NPT	22.20	20.60	14.25	15.90
110-N1-N5	3/4-14NPT	1/8-27NPT	27.00	23.90	15.90	8.75
110-N2-N5	3/4-14NPT	1/4-18NPT	27.00	23.90	15.75	12.70
110-N3-N5	3/4-14NPT	3/8-18NPT	27.00	23.90	15.75	15.90
110-N4-N5	3/4-14NPT	1/2-14NPT	27.00	23.90	15.75	19.05

**MILLIMETERS**  
 UNLESS OTHERWISE SPECIFIED  
 DO NOT SCALE DRAWING  
 ALL DIMENSIONS ARE IN MILLIMETERS  
 ALL TWO PLACE DECIMAL DIMENSIONS ± 0.05  
 REMOVE ALL BURRS AND SHARP CORNERS.