

MATERIAL:	BRASS
SURFACE:	PLAIN FINISH

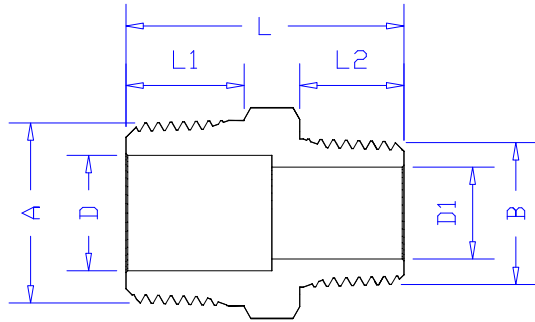

VIEW: B-B

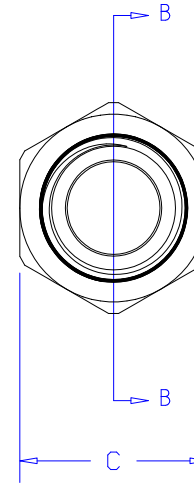

	A	B	C	L	L1	L2	D	D1
123-N1-N2	1/4-18NPT	1/8-27NPT	0.56"	1.02"	0.43"	0.37"	0.34"	0.22"
123-N1-N3	3/8-18NPT	1/8-27NPT	0.69"	1.12"	0.51"	0.38"	0.45"	0.22"
123-N2-N3	3/8-18NPT	1/4-18NPT	0.69"	1.18"	0.50"	0.43"	0.47"	0.34"
123-N2-N4	1/2-14NPT	1/4-18NPT	0.87"	1.22"	0.56"	0.43"	0.60"	0.34"
123-N3-N4	1/2-14NPT	3/8-18NPT	0.87"	1.36"	0.59"	0.51"	0.59"	0.45"
123-N4-N5	3/4-14NPT	1/2-14NPT	1.06"	1.57"	0.67"	0.59"	0.75"	0.56"

**INCHES**  
 UNLESS OTHERWISE SPECIFIED  
 DO NOT SCALE DRAWING.  
 ALL DIMENSIONS ARE IN INCHES  
 ALL TWO PLACE DECIMAL DIMENSIONS ± 0.05  
 REMOVE ALL BURRS AND SHARP CORNERS.