

MATERIAL:	BRASS
SURFACE:	PLAIN FINISH

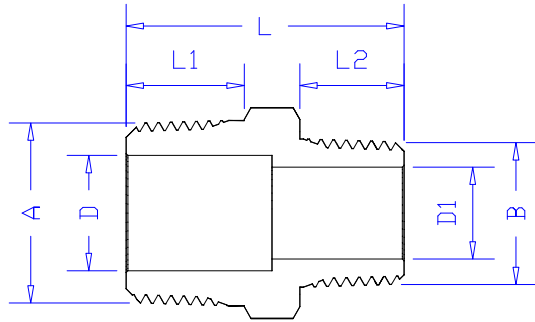

VIEW: B-B

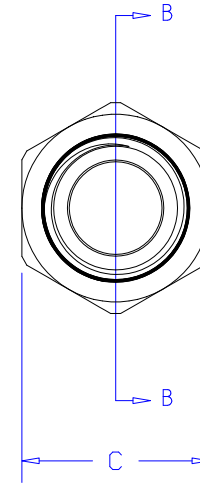

	A	B	C	L	L1	L2	D	D1
123-N1-N2	1/4-18NPT	1/8-27NPT	14.30	26.00	11.00	9.50	8.75	5.60
123-N1-N3	3/8-18NPT	1/8-27NPT	17.45	28.50	13.00	9.70	11.50	5.70
123-N2-N3	3/8-18NPT	1/4-18NPT	17.45	30.00	12.70	11.00	11.90	8.75
123-N2-N4	1/2-14NPT	1/4-18NPT	22.20	31.00	14.20	11.00	15.30	8.75
123-N3-N4	1/2-14NPT	3/8-18NPT	22.20	34.50	15.00	13.00	15.00	11.50
123-N4-N5	3/4-14NPT	1/2-14NPT	27.00	40.00	17.00	15.00	19.00	14.30

MILLIMETERS
 UNLESS OTHERWISE SPECIFIED
 DO NOT SCALE DRAWING
 ALL DIMENSIONS ARE IN MILLIMETERS
 ALL TWO PLACE DECIMAL DIMENSIONS ± 0.05
 REMOVE ALL BURRS AND SHARP CORNERS.