

MATERIAL:	BRASS
SURFACE:	PLAIN FINISH

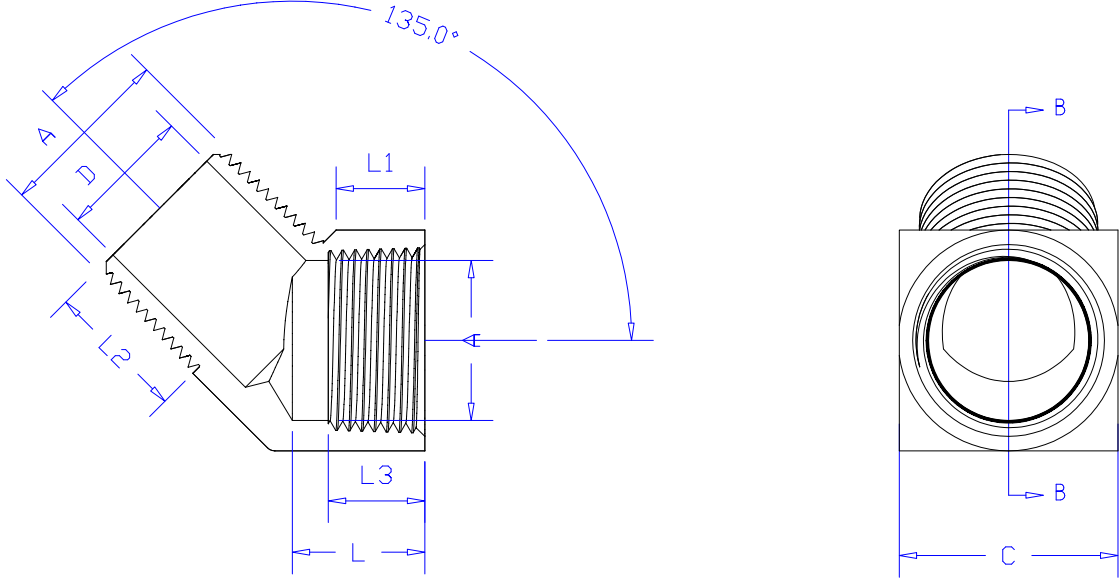

VIEW: B-B

	A	C	D	L	L1	L2	L3
124-N1	1/8-27NPT	0.55"	0.22"	0.41"	0.33"	0.37"	0.35"
124-N2	1/4-18NPT	0.71"	0.30"	0.51"	0.43"	0.44"	0.44"
124-N3	3/8-18NPT	0.85"	0.41"	0.51"	0.39"	0.45"	0.45"
124-N4	1/2-14NPT	1.02"	0.54"	0.71"	0.56"	0.57"	0.57"
124-N5	3/4-14NPT	1.24"	0.75"	0.81"	0.62"	0.62"	0.62"

INCHES
 UNLESS OTHERWISE SPECIFIED
 DO NOT SCALE DRAWING.
 ALL DIMENSIONS ARE IN INCHES
 ALL TWO PLACE DECIMAL DIMENSIONS ± 0.05
 REMOVE ALL BURRS AND SHARP CORNERS.